

# Sharples Trip Arm

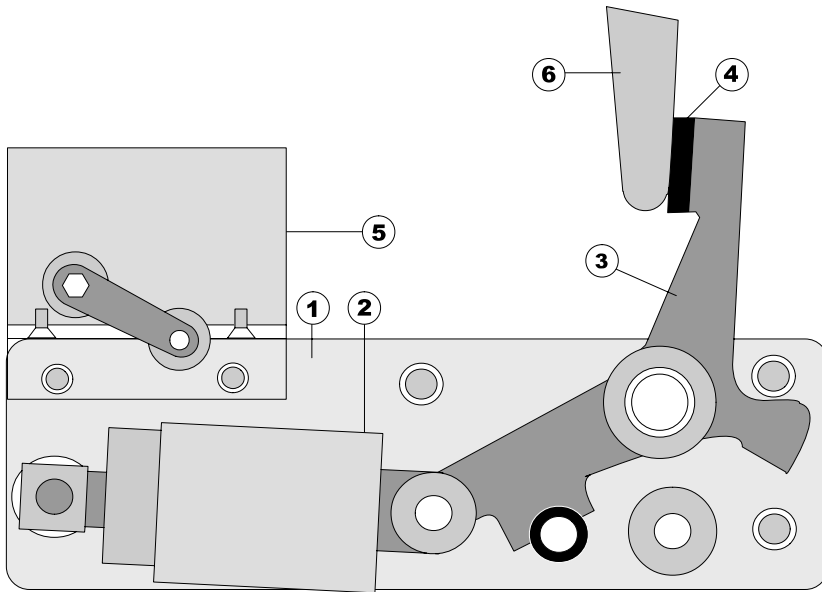

| # | Description                  | Part Number |
|---|------------------------------|-------------|
| 1 | Base Assembly .....          | 200007      |
| 2 | Compression Assembly .....   | 200006      |
| 3 | Torque Control Lever .....   | 201800      |
| 4 | Pad .....                    | 202000      |
| 5 | Micro Switch .....           | 200400      |
| 6 | Torque Arm .....             | 202300      |
| * | Complete Assembly .....      | 200001      |
|   | w/MicroSwitch & Torque Arm   |             |
| * | Complete Assembly .....      | 200002      |
|   | w/o MicroSwitch              |             |
| * | Complete Assembly .....      | 200003      |
|   | w/o MicroSwitch & Torque Arm |             |

